

ATLANTIS®



Atex CE  II 2 GD*
on request

art. B101 from DN 40 to DN 200 - GG25 / 304 / EPDM



art. B101	from DN 40 to DN 200 GG25 / 304 / EPDM
art. B10A	from DN 40 to DN 200 GG25 / GGG40 NICK / EPDM



art. B121	from DN 250 to DN 600 GG25 / 304 / EPDM
art. B12A	from DN 250 to DN 600 GG25 / GGG40 NICK / EPDM



art. B102	from DN 40 to DN 200 GG25 / 304 / NBR
-----------	--



art. B122	from DN 250 to DN 600 GG25 / 304 / NBR
-----------	---

MAIN STANDARD FEATURES:

CONSTRUCTION:

- **GENERAL SPECIFICATIONS:** BS EN 593 - (BS 5155) - MSS SP67 - API 609.
- **DIAMETERS:** DN40 - DN600.
- **CONNECTION WITH FLANGES UNI EN 1092:**
PN6 - PN10 - PN16 DN40 - DN300
PN10 DN350 - DN600.
- **CONNECTION WITH FLANGES ANSI 150:**
DN40 - DN300.
- **MAXIMUM WORKING PRESSURE:**
PN16 DN40 - DN300 (for fluids)
PN16 DN40 - DN200 (for gas)
PN10 DN350 - DN600 (for fluids)
PN10 DN250 - DN600 (for gas)
- **TEMPERATURE LIMITS WITH SEALING SEATS IN:**
EPDM -20°C / +110°C for fluids
NBR -20°C / +90°C for fluids
NBR -20°C / +60°C for gas
- **FACE TO FACE DIMENSIONS IN CONFORMITY WITH:**
UNI EN 558 - ISO5752 - MSS SP67 - API609 - DIN3202/3-K1.
- **TOP FLANGE:** drilling ISO5211.

- **OPERATION DEVICE:** lever DN40 - DN200,
gear DN250 - DN600.
- **LOCKING LEVER:** DN40 - DN200.
- Tested for vacuum at 900mbar.
- polyurethane coating.

- **NB:** for material compatibility please check the table with corrosion resistance at the end of the catalogue.

SPECIAL OPTIONS:

- Reduction gear with manual operation also for small DN.

ON REQUEST:

- Kit to convert from a manual valve to an actuated valve.
- For further special requests please consult our technical/commercial service.

ALLGEMEINE DATEN DER STANDARDAUSFÜHRUNG

BAUFORM:

- **ALLGEMEINE VORSCHRIFTEN:** BS EN 593 - (BS 5155) - MSS SP67 - API 609.
- **DURCHMESSER:** DN40 - DN600.
- **AUFFLANSCHBAR UNI EN 1092:**
PN6 - PN10 - PN16 DN40 - DN300
PN10 DN350 - DN600.
- **AUFFLANSCHBAR ANSI 150:**
DN40 - DN300.
- **MAXIMALER BETRIEBSDRUCK:**
PN16 DN40 - DN300 (für Flüssigkeiten)
PN16 DN40 - DN200 (für Gas)
PN10 DN350 - DN600 (für Flüssigkeiten)
PN10 DN250 - DN600 (für Gas)
- **TEMPERATURBEREICH MIT DICHTUNGSSITZEN AUS:**
EPDM -20°C / +110°C für Flüssigkeiten
NBR -20°C / +90°C für Flüssigkeiten
NBR -20°C / +60°C für Gas
- **BAULÄNGEN IN ÜBEREINSTIMMUNG MIT:**
UNI EN 558 - ISO5752 - MSS SP67 - API609 - DIN3202/3-K1.
- **OBERER FLANSCH:** mit Anschluss ISO5211.

- **BETÄTIGUNGSELEMENT:** Handhebel von DN40 bis DN200,
Schneckengetriebe von DN250 bis DN600.
- **VERRIEGELBARER HEBEL:** DN40 - DN200.
- Geeignet für Vakuum bis 900mbar.
- Polyurethanbeschichtung.

- **NB:** Für die Werkstoffkompatibilität wird auf die Tabelle mit den Korrosionsbeständigkeitswerten am Ende des Katalogs verwiesen.

SONDERAUSFÜHRUNGEN:

- Schneckengetriebe mit Handbetätigung auch für kleine DN.

AUF ANFRAGE:

- Umbaukit von Rasthandhebel auf Klappe für Stellantriebe.
- Für weitere Sonderanfragen bitte unsere Vertriebsabteilung kontaktieren.

LIST OF VALVE COMPONENTS AND MATERIALS / TEILE- UND WERKSTOFFLISTE DES VENTILS ARTIKEL

REF.	PART. / TEIL	Q.TY MENGE	MATERIALS / WERKSTOFFE		
			B101 B121	B10A B12A	B102 B122
1	BODY / GEHÄUSE	1	GG25/ASTM A126-B		
2	PLUG / VERSCHLUSS	1	C.S. NICK	C.S. NICK	C.S. NICK
3	DISC / SCHEIBE	1	CF8	GGG40N	CF8
4	SHAFT / WELLE	1	Type 410	Type 410	Type 410
4A	LOWER SHAFT / UNTERWELLE	1	Type 410	Type 410	Type 410
5	SEAT / SITZRING	1	EPDM	EPDM	NBR
10	UPPER SEAL / OBERE ABDICHTUNG	2	EPDM	EPDM	NBR
11	BUSHING / STOPFBUCHSE	1	Delrin	Delrin	Delrin
12	RING / RING	1	STEEL	STEEL	STEEL
19	SCREW / SCHRAUBE	2	C.S. NICK	C.S. NICK	C.S. NICK
51	WASHER / U-SCHEIBE	1	C.S. NICK	C.S. NICK	C.S. NICK
18	LEVER HANDLE / HANDHEBEL	1	CARBON STEEL		
18	REDUCTION GEAR / SCHNECKENGETRIEBE MIT HANDRAD	1	CAST IRON GG25 / GUSSEISEN GG25		

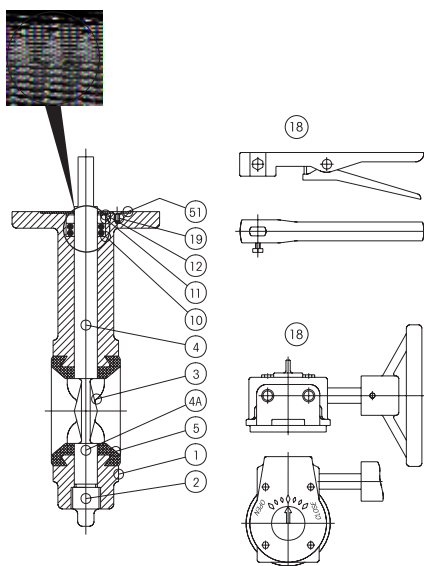

SECTION / QUERSCHNITT

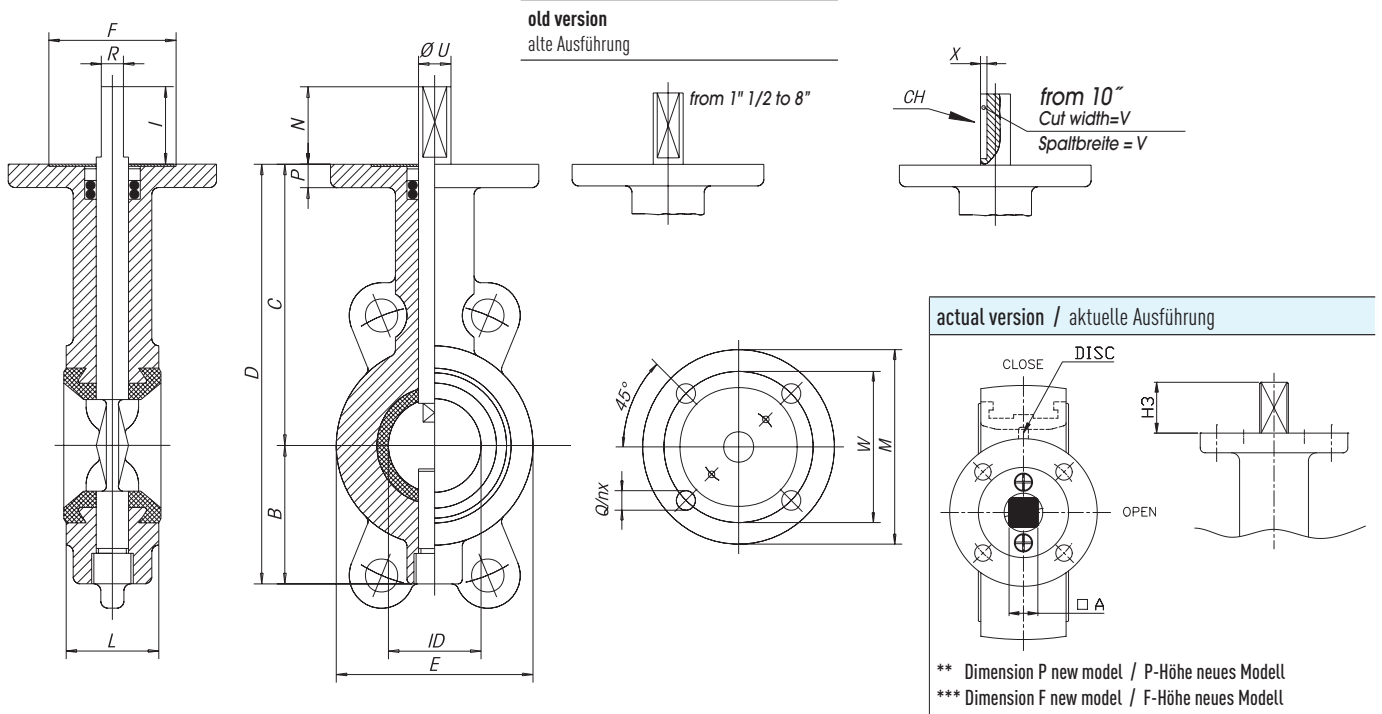

SIZE	BODY / GEHÄUSE								SHAFT / WELLE								ISO5211 CONNECTION / ANSCHLUSS ISO 5211								*	
	ID	L	B	C	D	E	P	P**	N	I	R	ØU	H3	□A	X	V	CH	ATT. ISO	M	W	n	Q	F	F***		KG
1"1/2	40	40	40	59	120	179	85	10	12	33	30	9,5	14	33	11			F07	90	70	4	9	55	55	2,7	
2"	50	50	43	64	130	194	92	11	12	33	30	9,5	14	33	11			F07	90	70	4	9	55	55	2,9	
2"1/2	65	63	46	72	137	209	107	11	12	33	30	9,5	14	33	11			F07	90	70	4	9	55	55	4,1	
3"	80	77	46	85	156	241	122	11	12	33	30	11,8	16	33	11			F07	90	70	4	9	55	55	4,4	
4"	100	100	52	95	170	265	150	11	12	33	30	11,8	16	33	11			F07	90	70	4	9	55	55	4,7	
5"	125	125	56	110	185	295	179	12	12	33	30	14,5	19	33	14			F07	90	70	4	9	55	55	6,3	
6"	150	147	56	123	203	326	206	12	12	33	30	14,5	19	33	14			F07	90	70	4	9	55	55	7,9	
8"	200	198	60	168	238	406	257	13	12	33	30	14,5	19	33	14			F07	90	70	4	9	55	58	12,3	
10"	250	244	68	203	270	473	316	15	16	65	60		22	65	17	4	8	8x7	F10	125	102	4	12	72	72	19,5
12"	300	298	78	242	310	552	370	15	16	65	60		28	65	22	4	8	8x7	F10	125	102	4	12	72	72	30,5
14"	350	352	78	290	330	620	410	15		65	60		28			4	8	8x7	F10	125	102	4	12	72		41
16"	400	399,5	102	330	375	705	468	20		75	70		38			5	12	12x8	F14	175	140	4	18	80		62
20"	500	493,5	127	400	440	840	578	20		100	95		45			5,5	14	14x9	F16	210	165	4	22	90		111
24"	600	583	154	460	510	970	680	22		100	95		55			5,5	14	14x9	F16	210	165	4	22	105		210

* Weights refer to valve with bare shaft. / * Die Gewichte beziehen sich auf ein Ventil mit freier Achse.

	SIZE	A	B	L	KG	
	1"1/2	40	9.5	29	265	0,6
	2"	50	9.5	29	265	0,6
	2"1/2	65	9.5	29	265	0,6
	3"	80	12	29	265	0,6
	4"	100	12	29	265	0,6
	5"	125	15	29	265	0,6
	6"	150	15	29	265	0,6
	8"	200	15	29	315	0,7

	SIZE DN	COD.		
	40	50	65	RD1Y608
	80	100		RD1Y611
	125	150	200	RD1Y613
	250			RD1Y616
	300			RD1Y617
	350			RD1Y618
	400			RD1Y619
	500			RD1Y621
	600			RD1Y622

NUTS AND STUD DIMENSIONS / ABMESSUNGEN BOLZEN UND ZUGSTANGEN

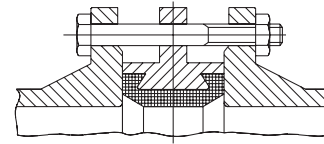
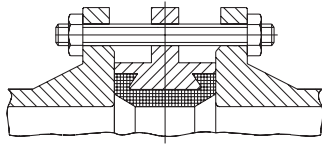

SIZE		PN10		PN16		ANSI150	
		Ø / L	N°	Ø / L	N°	Ø / L	N°
1"1/2	40	M16X110	4	M16X110	4	1/2" X 4"5/16	4
2"	50	M16X130	4	M16X130	4	5/8" X 5"1/8	4
2"1/2	65	M16X130	4	M16X130	4	5/8" X 5"1/8	4
3"	80	M16X140	8	M16X140	8	5/8" X 5"1/2	4
4"	100	M16X150	8	M16X150	8	5/8" X 5"1/2	8
5"	125	M16X150	8	M16X150	8	3/4" X 6"3/8	8
6"	150	M20X160	8	M20X160	8	3/4" X 6"3/8	8
8"	200	M20X170	8	M20X170	12	3/4" X 6"1/4	8
10"	250	M20X180	12	M24X190	12	7/8" X 7"1/2	12
12"	300	M20X190	12	M24X200	12	7/8" X 8"3/8	12
14"	350	M20X190	16	M24X220	16	1" X 8"3/4	12
16"	400	M24X230	16	M27X240	16	1" X 10"	16
20"	500	M24X250	20	M30X280	20	1"1/8 X 12"	20
24"	600	M24X300	20	M33X300	20	1"1/4 X 13"13/16	20

SIZE		PN10		PN16		ANSI150	
		Ø / L	N°	Ø / L	N°	Ø / L	N°
1"1/2	40	M16X90	4	M16X90	4	1/2" X 4"1/8	4
2"	50	M16X100	4	M16X100	4	5/8" X 4"1/4	4
2"1/2	65	M16X100	4	M16X100	4	5/8" X 4"3/4	4
3"	80	M16X100	8	M16X100	8	5/8" X 5"	4
4"	100	M16X110	8	M16X110	8	5/8" X 5"1/4	8
5"	125	M16X120	8	M16X120	8	3/4" X 5"1/2	8
6"	150	M20X120	8	M20X120	8	3/4" X 5"1/2	8
8"	200	M20X130	8	M20X130	12	3/4" X 6"	8
10"	250	M20X140	12	M24X150	12	7/8" X 6"1/2	12
12"	300	M20X160	12	M24X160	12	7/8" X 7"1/4	12
14"	350	M20X160	16	M24X170	16	1" X 8"	12
16"	400	M24X190	16	M27X200	16	1" X 8"3/4	16
20"	500	M24X200	20	M30X230	20	1"1/8 X 10"1/2	20
24"	600	M24X260	20	M33X270	20	1"1/4 X 12"	20

BREAKAWAY TORQUES in Nm / ANLAUFMOMENTE (LOSBRECHMOMENT) in Nm

PN - bar	DN size	40	50	65	80	100	125	150	200	250	300	350	400	500	600
		1"1/2	2"	2"1/2	3"	4"	5"	6"	8"	10"	12"	14"	16"	20"	24"
0		11	14	18	27	40	59	88	157	248	343	485	662	1142	2385
6		11	20	25	32	41	62	92	173	275	382	549	766	1327	2787
10		12	23	27	34	54	71	106	186	321	551	680	882	1634	3250
16		14	25	29	37	56	86	123	262	392	576				

The values in Nm may vary as a function of the seals material, temperature and type of medium. For a firm operation of the various types of actuators, in the different working conditions it is necessary to consider a safety factor of 1,5.

Die Nm-Werte sind abhängig von dem Material der Sitzringe, der Temperatur und Art von Flüssigkeit. Für die Gewährleistung der Funktionssicherheit der verschiedenen Arten von Servosteuerung unter verschiedenen Einsatzbedingungen ist ein Sicherheitsfaktor von = 1,5 zu berücksichtigen.

Kv AND Cv VALUES AS A FUNCTION OF OPENING ANGLE / Kv- UND Cv-WERTE IN ABHÄNGIGKEIT DES ÖFFNUNGSWINKELS

SIZE		Kv AND Cv VALUES AS A FUNCTION OF OPENING ANGLE / Kv- UND Cv-WERTE IN ABHÄNGIGKEIT DES ÖFFNUNGSWINKELS															
		20°		30°		40°		50°		60°		70°		80°		90°	
		Kv	Cv	Kv	Cv	Kv	Cv	Kv	Cv	Kv	Cv	Kv	Cv	Kv	Cv	Kv	Cv
1"1/2	40	2,6	3	4,3	5	9,5	11	16	18	22	26	39	45	60	70	69	80
2"	50	6,7	8	7,8	9	16	18	24	28	48	55	62	72	95	110	116	135
2"1/2	65	8,6	10	13	15	23	27	38	44	73	85	95	110	145	168	181	210
3"	80	13	15	20	23	34	39	56	65	112	130	142	165	216	250	267	310
4"	100	23	27	35	41	61	71	99	115	198	230	259	300	401	465	466	540
5"	125	50	58	74	86	129	150	211	245	414	480	526	610	845	980	948	1100
6"	150	83	96	121	140	211	245	345	400	677	785	871	1010	1392	1615	1647	1910
8"	200	142	165	211	245	354	410	591	685	1099	1275	1478	1715	2302	2670	2746	3185
10"	250	220	255	328	380	560	650	974	1130	1810	2100	2328	2700	3664	4250	4224	4900
12"	300	319	370	466	540	819	950	1353	1570	2629	3050	3405	3950	5129	5950	6336	7350
14"	350	388	450	647	750	1120	1300	1905	2210	3517	4080	4836	5610	6964	8078	9655	11200
16"	400	552	640	776	900	1483	1720	2405	2790	4310	5000	6336	7650	9284	10770	11121	12900
20"	500	785	910	1375	1595	2457	2850	3991	4630	7414	8600	9914	11500	15121	17540	19310	22400
24"	600	1078	1250	1974	2290	3448	4000	5250	6090	10776	12500	14224	16500	20336	23590	24397	28300